

Compact Joystick Advanced RNET

Code(s):

0033-7001a CJA-RNET

1 General

The **Compact Joystick Advanced R-Net** (CJA-RNET) is an input devices and is coupled to the R-NET wheelchair electronics.

- It is proportional joystick modules in a small housing.
- The joystick D50800 from PG Drive Technology is used. It is a very reliable contactless joystick which meets the most rigid requirements
- The CJA-RNET can be adjusted to any individual need and possibility of the user. This can be done by adjusting the 'Throw' parameters of the R-NET system.
- We can install the CJA-RNET in a good position through the mounting kit.
- Because the CJA-RNET has a standard shaft diameter, it will accept adaptive knobs available on the market.
- The CJA-RNET can be directly connected to the R-NET system.
- The CJA-RNET is completely protected against moisture, which makes it suitable to use outdoors.



2 Operation

2.1 Introduction

The CJA-RNET is a joystick module that can directly be connected to the R-NET control system of **PG Drives Technology** (PDGT). So we refer to the R-NET Control System Technical Manual – SK77981 – from PGDT.

The relevant contents of this chapter should be included in the wheelchair operating guide. Further copies are available from HMC International in either written or disk (Adobe PDF) format. Copies of the SK77981 of PGDT are available from PGDT in either written or disk (Adobe PDF) format. Copies of these 2 documents should not be made without the expressed permission of HMC International or PGDT.

The operation of the R-net varies dependent on programming. This chapter covers the special types of operation for the CJA-RNET. For a complete description of the system we refer again to the SK77981 of PGDT. It is the responsibility of the wheelchair manufacturer or local dealer to ensure that only the relevant sections of this chapter are included in the wheelchair's operating manual.

Please read this chapter carefully - it will help you to keep your wheelchair reliable and safe.

2.2 General

An R-net control system comprises a minimum of two modules - Joystick Module and Power Module. Because of the modular design, the depth of the control system can be greatly increased. The following diagram shows the basic set-up.

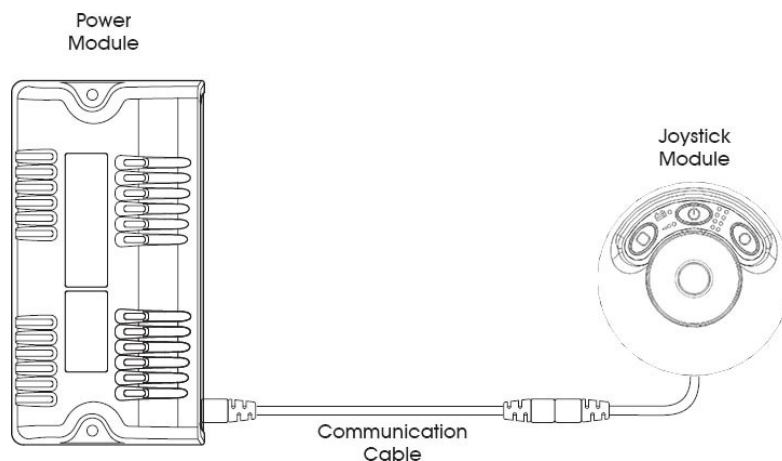

2.2.1 Handling

Avoid knocking your control system and especially the joystick. Be careful not to strike obstacles with the control system or joystick when you drive. Never drop the control system.

When transporting your wheelchair, make sure that the control system is well protected. Avoid damage to cables.

2.2.2 Operating Conditions

Your control system uses industrial-grade components throughout, ensuring reliable operation in a wide range of conditions. However, you will improve the reliability of the control system if you keep exposure to extreme conditions to a minimum.

Do not expose your control system or its components to damp for prolonged periods. If the control system becomes contaminated with food or drink clean it off as soon as possible.

2.2.3 Cleaning

Clean the control system and the joystick with a cloth dampened with diluted detergent. Be careful when cleaning the joystick.

Never use abrasive or spirit-based cleaners.

2.3 Mating Connectors

To connect the Communication Cables:

Holding the connector housing, firmly push the connector into its mate until you can no longer see the yellow plastic.

The connectors are secured using a friction system.

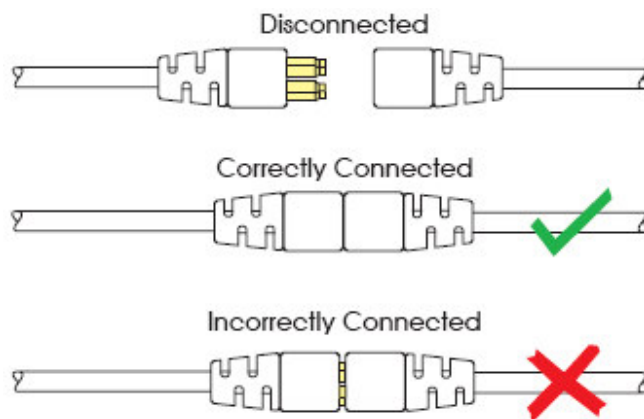

To disconnect the Communication Cables:

Holding the connector housing firmly, pull the connectors apart.

2.4 Controls

Most of the controls of the CJA-RNET are common to the standard joystick module of PGDT. The controls typical for the CJA-RNET are explained in this section. For the complete description we refer to the SK77981 of PGDT.

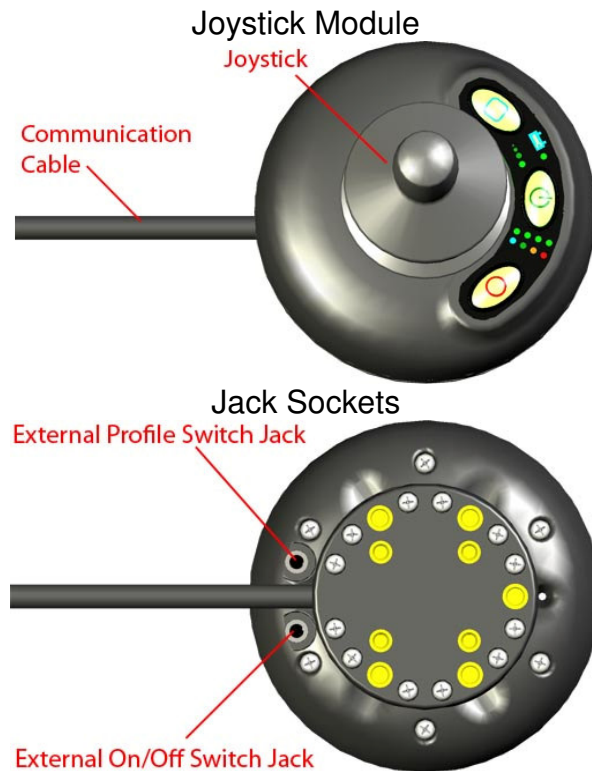

2.4.1 Joystick

The primary function of the joystick is to control the speed and direction of the wheelchair. The further you push the joystick from the centre position the faster the wheelchair will move. When you release the joystick the brakes are automatically applied. If the wheelchair is fitted with actuators, the joystick can also be used to move and select actuators, refer to section 4.3 for more details.

2.4.2 Buttons and Led's

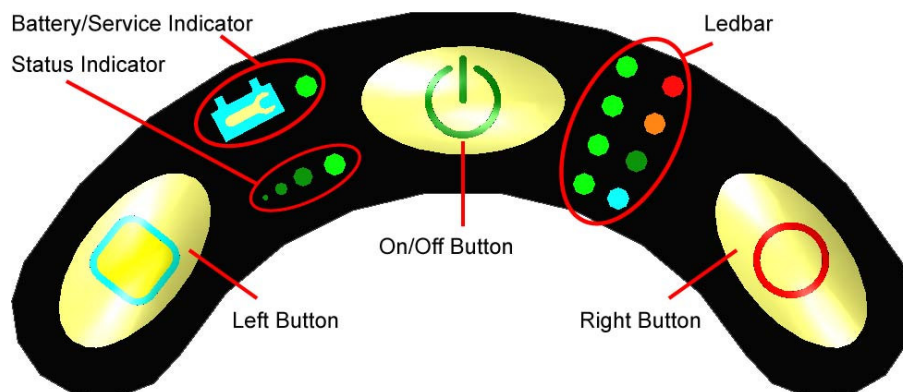

2.4.2.1 On/Off Button

The On/Off button applies power to the control system electronics, which in turn supply power to the wheelchair's motors.

Do not use the On/Off button to stop the wheelchair unless there is an emergency. (If you do, you may shorten the life of the wheelchair drive components).

2.4.2.2 Left Button

Depending on the way the control system has been programmed this key can have different functions. The factory default function is 'Mode Drive/Axes'. The 'Mode Drive/Axes' function allows the user to switch between the drive mode and local axes mode. We refer to the program manual for further details.

2.4.2.3 Right Button

Depending on the way the control system has been programmed this key can have different functions. The factory default function is 'Next'. The function 'Next' allows the user to select the next profile or the next output depending in which mode you are at that moment. We refer to the program manual for further details.

2.4.2.4 External On/Off Switch Jack

This allows the user to turn the control system on and off using an external device, such as a buddy button.

2.4.2.5 External Profile Switch Jack

Depending on the way the control system has been programmed an external connected device, such as a buddy button, can have different functions. The factory default function is 'Horn'. The horn will sound while the connected switch is pressed – as long as the standard function is selected. We refer to the program manual for further details.

2.4.2.6 Battery/Service Indicator

In normal operating state this displays the charge available in the battery and can be used to alert the user to the status of the battery.

Green Continuous

This indicates that all is well. Battery level is >70%.

Green Long Flashing

This indicates that all is well. Battery level is between 50% and 70%.

Green Short Flashing

This indicates that all is well. Battery level is between 30% and 50%.

Red Continuous

The control system is functioning correctly, but you should charge the battery as soon as possible. Battery level is <30%.

In addition to the indication of the battery level, the Battery/Service Indicator displays:

Alternating Green/Red Flashing

The system is starting up. A reconfiguration and restart request is possible.

Red Flashing

The system has detected an inhibit. See CJA State Indication Chart.

Green Pulse with Red Failure Indication

The system has detected a failure. Service is required. See CJA State Indication Chart.

No Light

System is off.

2.4.2.7 Status Indicator

This displays the status of the joystick module.

Green Continuous

This indicates that the joystick is in drive mode. In this mode it is possible to drive and to change profile.

Green Flashing

This indicates that the joystick is in latched drive mode. In this mode it is possible to drive and to change profile.

Red Continuous

This indicates that the joystick is in non-driving mode. Depending on the depth of your system you can do various things. Operating your axes is maybe the best known one.

Red/Green Fast Flashing

This indicates that the joystick is in Drive Axis. See section 4.2.3 for more details

2.4.2.8 Led Bar

The Led Bar displays extra information about the status of the joystick module.

Normal drive or latched mode:

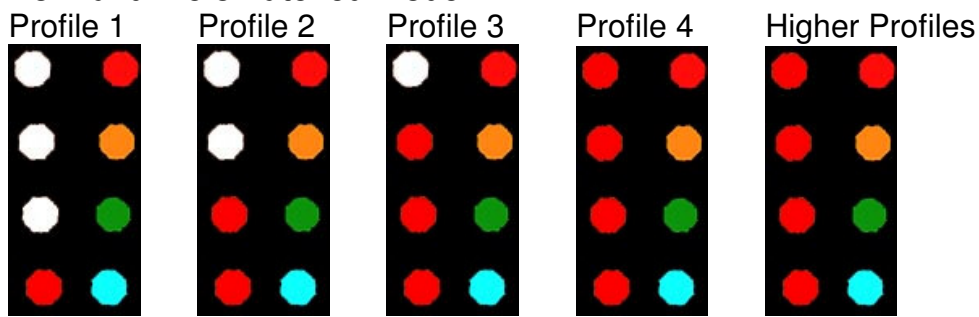

If the speed of the wheelchair is being limited; for example, by a raised seat, then the highest profile–4–LED indicator led will flash.

If the wheelchair is prohibit from driving; for example, be a raised seat, the profile indicator will turn off when the joystick is out of neutral. When the joystick is in neutral position, the led's will show the actual profile.

Joystick out of neutral



Local output mode:

The way to operate your actuators, lights or horn depends on how the CJA is programmed. Up to 16 different outputs (e.g. recline, left indicator, horn, etc.) can be programmed. The outputs are located in 4 groups and each group can contain up to 4 outputs.

If you enter the local output mode you need first to select a group. The group is indicated by a flashing led.

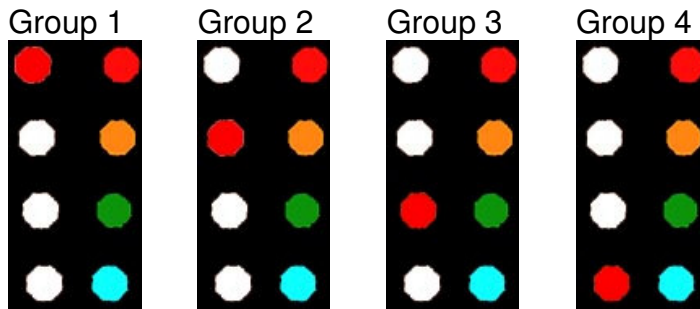

After you selected a group you can select the desired output. The output is indicated by a LED.

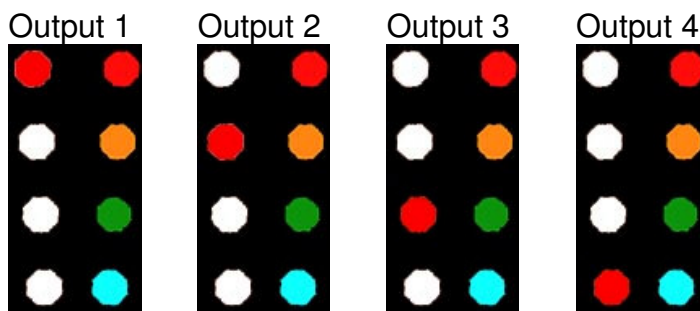

If your wheelchair is setup to use only up to 4 outputs in 1 group, the group selection is not needed.

2.5 Diagnostic Screen or Acoustic Feedback

When the control system safety circuits have operated and the control system has been prevented from moving the wheelchair, a diagnostics code will be displayed.

This indicates a system trip, i.e. the R-net has detected a problem somewhere in the wheelchair's electrical system.

All red LED's will flash periodically alternated with a green flash of the battery/service indicator. The number of red flashes is an indication of the fault. We refer to the State Indication Chart.

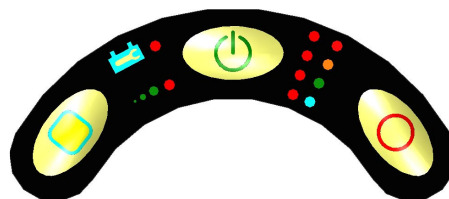

If the error is not critical, for example the ISM detects a broken light, then drive will still be possible, however, an acoustic signal will be produced intermittently.

2.6 Getting Ready to Drive

- Operate the on/off switch. The Battery/Service indicator and the Led Bar will go through an initializing process then show the base indications as follows.

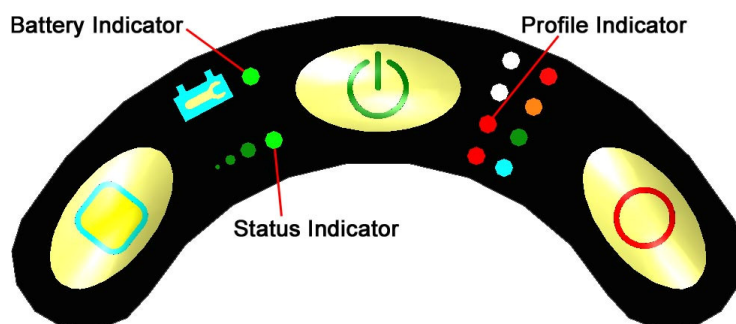

- Check that you select a profile which suits you.
- Push the joystick to control the speed and direction of the wheelchair.

Remark! If you push the joystick before or just after you switch the control system on, the Led Bar will not illuminate and the joystick will bleep. You must release and centre the joystick to resume normal operation.

2.7 Tips for Using your Control System

2.7.1 Driving - General

Make sure that the control system is mounted securely and that the joystick position is correct. The hand or limb you use to operate the joystick should be supported, for example by the joystick modules arm pad. Do not use the joystick as the sole support for your hand or limb - wheelchair movements and bumps could upset your control.

2.7.2 Driving Technique

The control system interprets your joystick movements and produces appropriate movements of your wheelchair. You will need very little concentration to control the wheelchair, which is especially useful if you are inexperienced. One popular technique is to simply point the joystick in the direction you want to go. The wheelchair will “home-in” on the direction you push the joystick.

The further you push the joystick away from the rest position, the faster the wheelchair will go. Releasing the joystick will stop the wheelchair.

The intelligent speed control system minimizes the effects of slopes and different types of terrain.

Remark! The wheelchair user must be capable of driving a wheelchair safely. HMC International NV accepts no liability for losses of any kind arising from failure to comply with this condition.

2.7.3 Slow or sluggish movement

If the wheelchair does not travel at full speed or does not respond quickly enough, and the battery condition is good, there may be a nonhazardous fault. Contact your service agent.

2.8 Precautions for Use

In the event of the wheelchair moving in an unexpected way **RELEASE THE JOYSTICK**. This action will stop the wheelchair under any circumstances.

2.8.1 Hazards

Do not drive the wheelchair:

- Beyond restrictions indicated in your wheelchair user manual, for example maximum inclines, curb height etc.
- In places or on surfaces where a loss of wheel grip could be hazardous, for example on wet grassy slopes.
- If you know that the control system or other crucial components require repair.

Although the R-net control system is designed to be extremely reliable and each unit is rigorously tested during manufacture, the possibility of a system malfunction always exists (however small the probability). Under some conditions of system malfunction the control system must (for safety reasons) stop the chair instantaneously. If there is any possibility of the user falling out of the chair as a result of a sudden braking action, it is imperative that a restraining device such as a seat belt is supplied with the wheelchair and that it is in use at all times when the wheelchair is in motion. HMC International NV accept no liability for losses of any kind arising from the unexpected stopping of the wheelchair or arising from the improper use of the wheelchair or control system.

Do not operate the control system if the chair behaves erratically, or shows abnormal signs of heating, sparks or smoke. Turn the control system off at once and consult your service agent. HMC International NV accepts no liability for losses of any kind arising from failure to comply with this condition.

Electronic equipment can be affected by Electro Magnetic Interference (EMI). Such interference may be generated by radio stations, TV stations, other radio transmitters and cellular phones. If the chair exhibits erratic behaviour due to EMI, turn the control system off immediately and consult your service agent. HMC International NV accepts no liability for losses of any kind arising from failure to comply with this condition.

It is the responsibility of the chair manufacturer to ensure that the wheelchair complies with appropriate National and International EMC legislation. HMC International NV accepts no liability for losses of any kind arising from failure to comply with this condition.

The wheelchair user must comply with all wheelchair safety warnings. HMC International NV accepts no liability for losses of any kind arising from failure to comply with this condition.

2.9 Safety Checks

The electronic circuits in your control system have been designed to be extremely safe and reliable. The on-board microcomputer carries out safety checks at up to 100 times per second. To supplement this safety monitoring you should carry out the following periodic checks.

If the control system fails any of these checks, do not use the wheelchair and contact your service agent.

2.9.1 Daily Checks

Joystick: - With the control system switched off, check that the joystick is not bent or damaged and that it returns to the centre when you push and release it. If there is a problem do not continue with the safety checks and contact your service agent.

2.9.2 Weekly Checks

Parking brake: - This test should be carried out on a level floor with at least one meter clear space around the wheelchair.
- Switch on the control system.
- Check that the LEDs remain on, after initialization and that the battery gauge is displaying a reasonable amount of charge.
- Push the joystick slowly forwards until you hear the parking brakes operate. The chair may start to move.
- Immediately release the joystick. You must be able to hear each parking brake operate within a few seconds.
- Repeat the test a further three times, pushing the joystick slowly backwards, left and right.

Connectors: - Make sure that all connectors are securely mated.

Cables: - Check the condition of all cables and connectors for damage.

Joystick gaiter: - Check the thin rubber gaiter or boot, around the base of the joystick shaft, for damage or splitting. Check visually only, do not handle the gaiter.

Mounting: - Make sure that all the components of the control system are securely mounted. Do not overtighten any securing screws.

2.9.3 Servicing

To ensure continued satisfactory service, we suggest you have your wheelchair and control system inspected by your service agent after a period of 1 year from commencement of service. Contact your service agent for details when the inspection is due.

2.10 Programming

The control system can be programmed to meet your needs. Programming can be performed using the R-net programmer software and dongle/programming key. If you re-program your control system, make sure that you observe any restrictions given in your wheelchair user manual. Note any changes you make for future reference.

Remark! Programming should only be conducted by healthcare professionals with in-depth knowledge of PGDT electronic control systems and the CJA-RNET. Incorrect programming could result in an unsafe set-up of a wheelchair for a user. HMC International NV accepts no liability for losses of any kind if the programming of the control system is altered from factory pre-set values.

2.11 Servicing

All repairs and servicing must be carried out by authorized service personnel. Opening or making any unauthorized adjustments or modifications to the control system or its components will invalidate any warranty and may result in hazards to yourself or other people, and is strictly forbidden.

HMC International NV accepts no liability for losses of any kind arising from unauthorized opening, adjustment or modifications to the R-net control system.

If the control system is damaged in any way, or if internal damage may have occurred through impact or dropping, have the product checked by qualified personnel before operating. HMC International NV accepts no liability for losses of any kind arising from failure to comply with this condition.

2.12 Warranty

The CJA-RNET is covered by a warranty period defined by the service agent. For details of the warranty period, please contact your service agent.

The warranty will be void if the CJA-RNET has:

- Not been used in accordance with the CJA-RNET user manual – this manual – of HMC International.
- Not been used in accordance with the R-net control system Technical Manual, SK77981, of PGDT.
- Been subject to misuse or abuse.
- Been modified or repaired by non-authorized persons.

3 Installation

3.1 R-Net Operation

Study Chapter 2. It is important that the operation information in Chapter 2 is supplied, either as part of the wheelchair user handbook or as a separate document.

3.2 Program Settings

It is the wheelchair manufacturer's or dealer responsibility to program the control system to suit the vehicle model and ensure safe operation in compliance with relevant legal requirements over the whole of the operating range. HMC International NV accepts no liability for losses of any kind due to failure to, or incorrect programming of the R-net Control System. Refer to Chapter 4 for programming details.

Programming should only be conducted by healthcare professionals with in-depth knowledge of PGDT electronic control systems and of the CJA-RNET of HMC International NV. Incorrect programming could result in an unsafe setup of a wheelchair for the user.

3.3 Connections

The following is a selection of the most common configurations

3.3.1 Control Configurations

3.3.1.1 Basic Configuration

Consists of a Power Module, a Communication Cable and a Joystick Module.

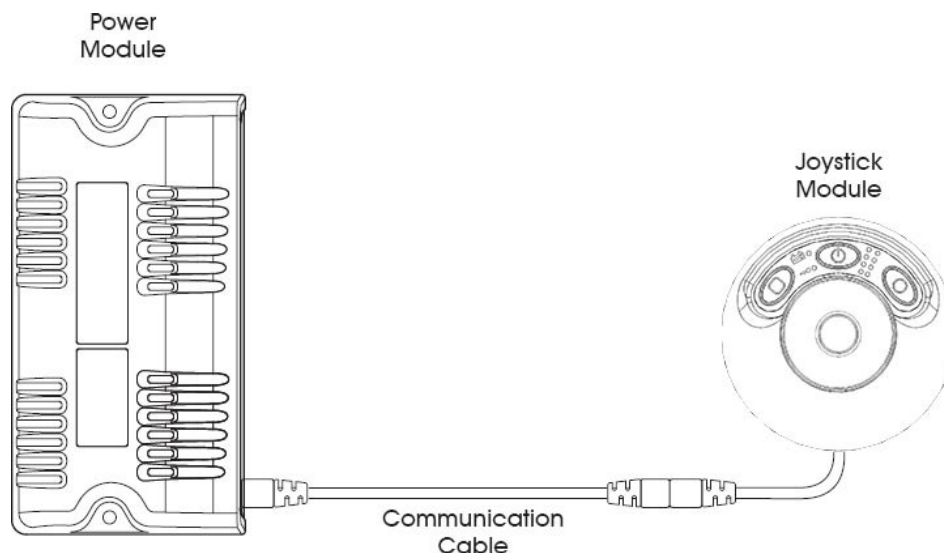

3.3.1.2 Joystick & ISM Configuration

This consists of a Power Module, an Intelligent Seating/Lighting Module (ISM), 2 Communication Cables and a Joystick Module.

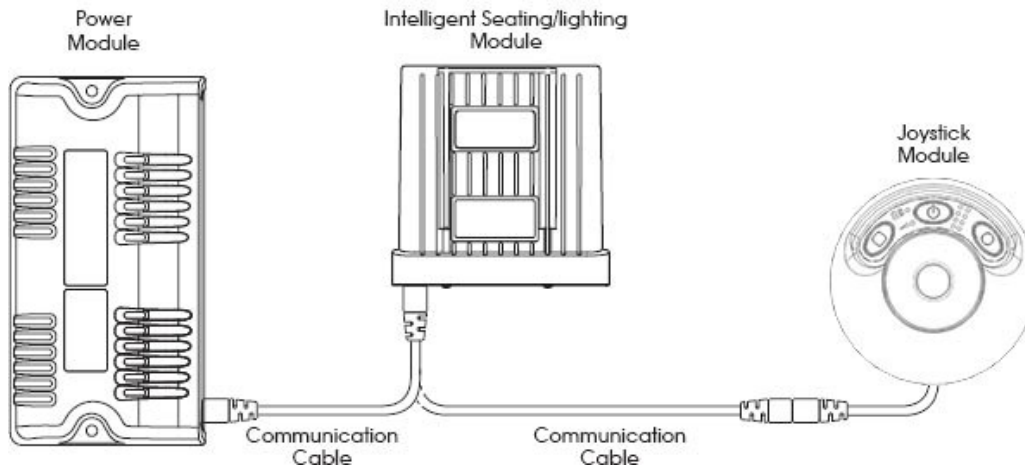

3.4 Mounting

3.4.1 Joystick Module Mounting

3.4.1.1 General

The Joystick Module should be secured using M4 screws with a maximum penetration of 8mm or M5 screws with a maximum penetration of 10mm. The M4 screws have a pitch circular diameter (PCD) of 32mm. The M5 screws 1-3-5 and 2-4 have a distance between each other of 40mm.

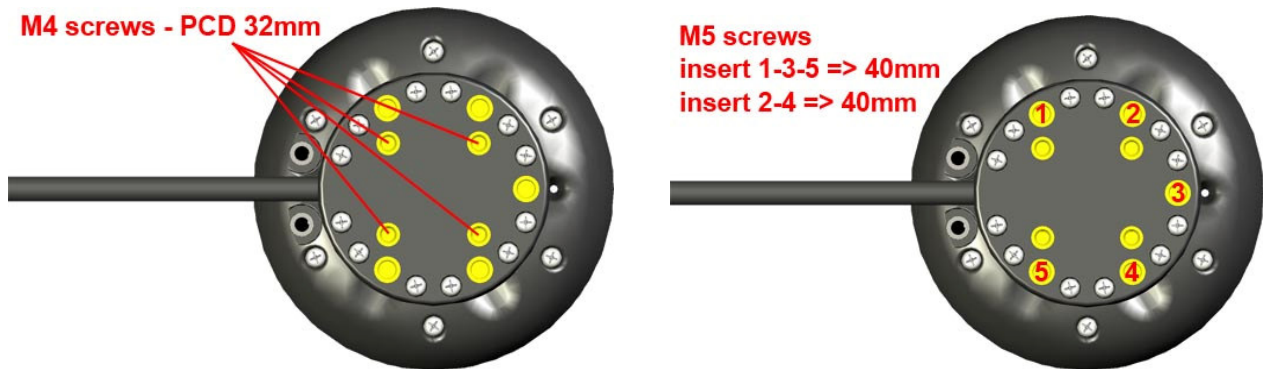

3.4.2 Power Module and ISM Mounting

We refer to the R-NET Control System Technical Manual – SK77981 – of PGDT.

3.4.3 Cables

The cables to the different modules must be routed and secured in such a way as to prevent damage to them, for example by cutting or crushing. Contact HMC International NV if you need further advice.

3.5 Joystick Module Wiring

The Joystick Module is connected to the Power Module with a Communication Cable.

To connect the Communication Cables:

- Holding the connector housing, firmly push the connector into its mate until you can no longer see the yellow plastic. The connectors are secured using a friction system.

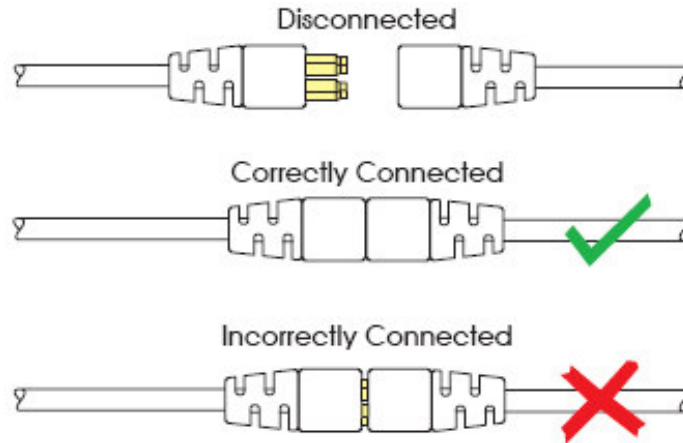

To disconnect the Communication Cables:

- Holding the connector housing firmly, pull the connectors apart.

3.6 Power Module & ISM Wiring

We refer to the R-NET Control System Technical Manual – SK77981 – of PGDT.

3.7 Functionality Tests

Perform the following tests, in order, on each wheelchair before dispatch.

These tests should be conducted in an open space and a restraining device such as a seat belt should always be used. HMC International NV accepts no liability for losses of any kind arising from failure to comply with this condition.

3.7.1 Joystick and Gaiter

- Check that the joystick is not bent or damaged.
- Check the thin rubber gaiter or boot, around the base of the joystick shaft, for damage or splitting. Check visually only, do not handle the gaiter.
- Check that the joystick returns to the centre position when you push and release it.

3.7.2 Operational Test

This test should be carried out on a level floor with at least one meter clear space around the wheelchair.

- Switch on the control system.
- Check that the battery gauge remains on, or flashes, after one second.
- Push the joystick slowly forwards until you hear the parking brakes operate. The chair may start to move.
- Immediately release the joystick. You must be able to hear each parking brake operate within a few seconds.
- Repeat the test a further three times, pushing the joystick slowly backwards, left and right.

3.7.3 Test Drive

- Drive the wheelchair and make sure that it operates correctly for all positions of the user controls.

3.7.4 Soft-Stop Test

- Drive the wheelchair at full forward speed and switch the control system off.
- The wheelchair must not stop suddenly, but should decelerate to standstill.

3.8 Electromagnetic Compatibility (E.M.C.)

The CJA-RNET has been tested on a generic wheelchair for compliance with EC directive 89/336/EEC, and the EMC requirements of EN12184. You, as wheelchair manufacturer or dealer, should consider EMC and perform relevant tests if necessary.

3.9 Battery Gauge

Refer to Chapter 2 for how to read the battery gauge.

The battery gauge becomes red when the battery voltage falls below 23.3V whilst the wheelchair is driving on a level surface.

4 Table of Content:

1	General.....	1
2	Operation.....	2
2.1	Introduction.....	2
2.2	General.....	2
2.2.1	Handling.....	2
2.2.2	Operating Conditions.....	3
2.2.3	Cleaning.....	3
2.3	Mating Connectors.....	3
2.4	Controls.....	4
2.4.1	Joystick.....	4
2.4.2	Buttons and Led's.....	4
2.4.2.1	On/Off Button.....	5
2.4.2.2	Left Button.....	5
2.4.2.3	Right Button.....	5
2.4.2.4	External On/Off Switch Jack.....	5
2.4.2.5	External Profile Switch Jack.....	5
2.4.2.6	Battery/Service Indicator.....	5
2.4.2.7	Status Indicator.....	6
2.4.2.8	Led Bar.....	6
2.5	Diagnostic Screen or Acoustic Feedback.....	7
2.6	Getting Ready to Drive.....	8
2.7	Tips for Using your Control System.....	8
2.7.1	Driving - General.....	8
2.7.2	Driving Technique.....	8
2.7.3	Slow or sluggish movement.....	8
2.8	Precautions for Use.....	9
2.8.1	Hazards.....	9
2.9	Safety Checks.....	10
2.9.1	Daily Checks.....	10
2.9.2	Weekly Checks.....	10
2.9.3	Servicing.....	10
2.10	Programming.....	11
2.11	Servicing.....	11
2.12	Warranty.....	11
3	Installation.....	12
3.1	R-Net Operation.....	12
3.2	Program Settings.....	12
3.3	Connections.....	12
3.3.1	Control Configurations.....	12
3.3.1.1	Basic Configuration.....	12
3.3.1.2	Joystick & ISM Configuration.....	13
3.4	Mounting.....	13
3.4.1	Joystick Module Mounting.....	13
3.4.1.1	General.....	13
3.4.2	Power Module and ISM Mounting.....	13
3.4.3	Cables.....	13
3.5	Joystick Module Wiring.....	14

3.6	Power Module & ISM Wiring.....	14
3.7	Functionality Tests.....	15
3.7.1	Joystick and Gaiter.....	15
3.7.2	Operational Test.....	15
3.7.3	Test Drive.....	15
3.7.4	Soft-Stop Test.....	15
3.8	Electromagnetic Compatibility (E.M.C.).....	15
3.9	Battery Gauge.....	15
4	Table of Content:.....	16